



landscape • entertainment • architectural • hospitality • illumination

PL-22 SERIES DIRECTIONAL LIGHT



PL-22-LEDP12V-CAM



PL-22-LEDP12V-WTX



PL-22-LEDP12V-BAR



PATH LIGHTS PL-22 SERIES



TYPE

SPECIFICATIONS

CONSTRUCTION: Extruded 2.25" square aluminum or brass.

LENS: High temperature white acrylic

LAMP SUPPLIED: 18w S8 #1141; 1200 hours average rating (25w max.)

LAMP OPTIONS: We recommend 3w 50,000 hours average rating OMNI-3 LED (-LED3) or OMNI-3 Super Saver (-LED3SS) 10,000 hours average rating 20w Xenon (-X) or 20w Halogen (-H)

SOCKET: Single contact bayonet, brass nickel plated lamp socket screw shell (Ba15s); double contact bayonet base (Ba15d) for 120v, both with 200° C silicone lead wires.

No socket for LED Panel models

LED PANEL OPTION: 12v, 4w, 300 lumen integrated LED flat panel, warm white 3000K (-LEDP); optional cool white 5200K 320 lumen available (modify part number to -LEDP52)

LED LIFETIME RATING: 50,000 Hours

LED INTERNAL DRIVER*: 4w 350mA output, 12v AC input. Voltage range of 9 to 18 volts with optimum operating range of 10 to 15 volts for consistent performance and brightness. For use with magnetic transformers only.

WIRING: Black 3 foot 18/2 zip cord from base of fixture (12v only)
For 25 foot 16/2 fixture lead wire add -25F to catalog number.
120v standard wiring

CONNECTION: FA-05 Quick Connector (not supplied) from fixture to main cable (12/2, 10/2 or 8/2 only) 12v only

MOUNTING: Angle cut post (PL-22)
FA-03 black 9" ABS stake, tapped 1/2" NPS (PL-22-DM)

FINISH: Aluminum - Black texture polyester powder coat. Optional finishes available
Brass - Unfinished brass. Optional finishes available

*NOTE: Optional 120v to 277v drivers available. Must use FA-26 mounting post or junction box



ORDERING INFORMATION

CATALOG NO.	DESCRIPTION	LAMP	SHIP WEIGHT
PL-22-BLT	Square Aluminum Bollard	18w S8 #1141	3.0 lbs.
PL-22-BRS	Square Brass Bollard	18w S8 #1141	6.0 lbs.
PL-22-DM-BLT	Square Aluminum Bollard, Deck Mount	18w S8 #1141	3.0 lbs.
PL-22-DM-BRS	Square Brass Bollard, Deck Mount	18w S8 #1141	6.0 lbs.

IP54



MOUNTING ACCESSORIES

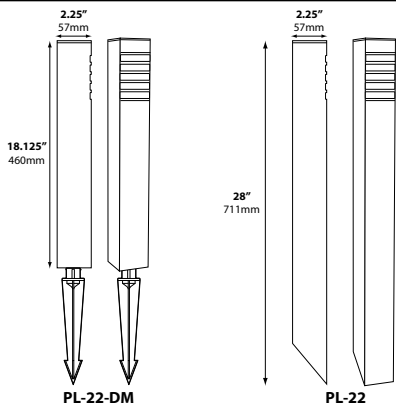
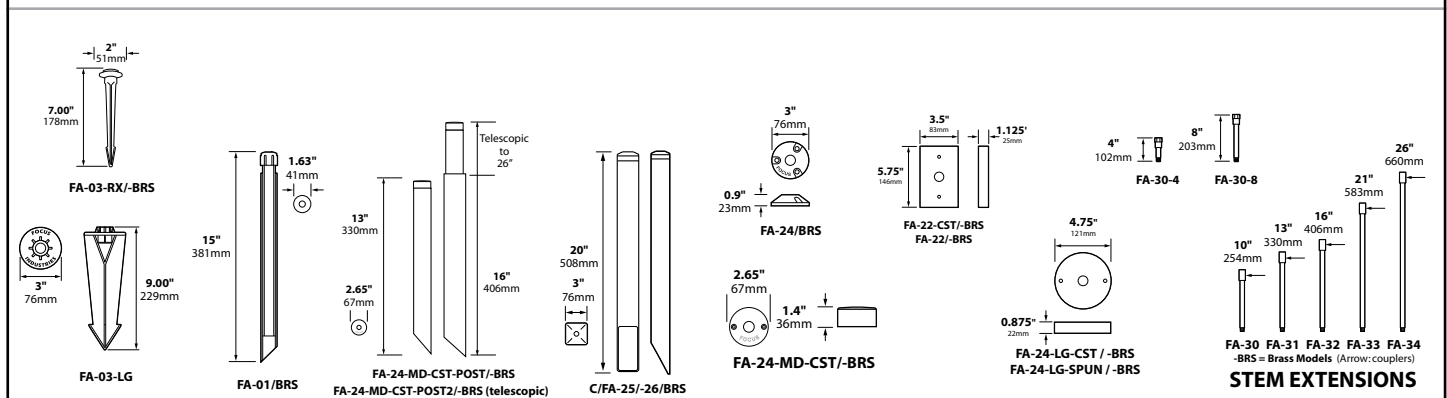

JOB INFORMATION

Type: _____ Date: _____

Job Name: _____

Cat. No.: _____

Lamp(s): _____

Specifier: _____

Contractor: _____

Notes: _____

FOCUS INDUSTRIES INC.
25301 COMMERCENTRE DRIVE
LAKE FOREST, CA 92630

www.focusindustries.com
sales@focusindustries.com
(949) 830-1350 • FAX (949) 830-3390

Black Texture (Standard)	Antique Verde	Bronze Texture	Camel	White Texture	Hunter Texture	Rust	Weathered Iron	Weathered Brown	Stucco	Rubbed Verde	Chrome Powder	Acid Rust	Acid Verde	Black Acid Treatment
-BLT	-ATV	-BRT	-CAM	-WTX	-HTX	-RST	-WIR	-WBR	-STU	-RBV	-CPR	-BAR/CAR	-BAV/CAV	-BAT