

# HID-110-H-EX39-840-BYP-SB



Replace 250 - 400W HID lamps for shoebox area lights. Water/dust resistant. LED uses approximately 76% less energy than traditional HID lamps. Expandable flaps and rotatable base.

Color: White

Weight: 3.6 lbs

**Project:**

**Type:**

**Prepared By:**

**Date:**

## Driver Info

Watts 110W  
 Color Temp 4000K (Cool White)  
 Lumens 13,800  
 Efficacy 125.5 LPW  
 Color Accuracy 80 CRI  
 L70 Accuracy 50,000

## LED Info

Input Voltage 100-277V  
 Power Factor 0.9  
 Flicker <30%  
 THDi <20%  
 R9

## Technical Specifications

### Listings

**UL Listed:**

Yes

**UL Classified:**

Yes

**FCC:**

Yes

**Rohs:**

Yes

**CEC Status:**

Lawful for sale in California

**DLC Qualified:**

Yes

**DLC Listed:**

This product is on the Design Lights Consortium (DLC) Qualified Products List and is eligible for rebates from DLC Member Utilities. DLC Product Code: P0J6172M

### Description

**Lamp Type:**

HID

**Bulb Type:**

Shoe Box

**Base Type:**

EX39, Mogul Base

**Dimmable:**

No

### Construction

**Operating Temperature:**

-20 - 40°C

**Bare Lamp Illuminated Length (inches):**

7.17"

**MOL (inches):**

11.1"

### MOD (inches):

4.92"

### Minimum Compartment Size (inches):

Length: 11.02"

Width: 11.02"

Height: 9.84"

### LED Characteristics

**Lifespan:**

50,000-hour LED lifespan based on IES LM-70 results

### Optical

**Beam Angle:**

180°

### Other

**Warranty:**

5-years

# HID-110-H-EX39-840-BYP-SB

## Technical Specifications (continued)

### Other

#### Accessories:

Surge protector available. Click [here](#) for surge protector accessory. Sold separately.

### Shipping Information

#### Case Qty:

6

#### Case Dimensions:

17.52 x 13.27 x 13.58

#### Pallet Quantity of Pieces:

72

#### Pallet Dimensions:

28.5 x 37.01 x 45.47

## Dimensions

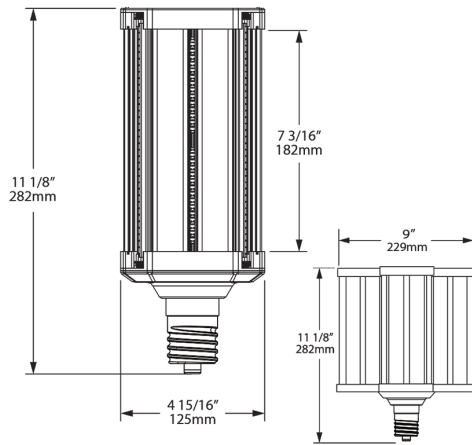

## Features

- HID REPLACEMENT - Replacement for conventional HID lamps
- BALLAST BYPASS - Internal driver eliminates the need for external driver or ballast
- COMPACT DESIGN - Allows the lamp to fit in most fixtures
- EXPANDABLE FLAPS - Provides the light where you need it
- HEAT DISSIPATION - Thermal technology extends lifespan
- WATER & DUST RESISTANT - Ideal for outdoor fixtures
- ENCLOSED FIXTURE RATED - May be used in enclosed and open fixtures
- ENERGY SAVINGS - Uses 76% less energy than traditional lamps
- SURGE PROTECTION - Includes 4kV surge protection
- MERCURY FREE - Environmentally friendly vs fluorescent technologies
- 350°; ROTATABLE BASE - Direct light where needed

## Ordering Matrix

Family	Lamp Power	Orientation	Base Type	CRI	Color Temp	Installation Type	Lamp Type
HID	110	H	EX39	8	40	BYP	SB
	80 = 320W 110 = 400W	H = Horizontal	EX39 = EX39	8 = 80 CRI	30 = 3000K 40 = 4000K 50 = 5000K	BYP = Bypass	SB = Shoebox

# HID-110-H-EX39-850-BYP-SB



Replace 250 - 400W HID lamps for shoebox area lights. Water/dust resistant. LED uses approximately 76% less energy than traditional HID lamps. Expandable flaps and rotatable base.

Color: White

Weight: 3.6 lbs

**Project:**

**Type:**

**Prepared By:**

**Date:**

## Driver Info

Watts 110W  
 Color Temp 5000K (Daylight)  
 Lumens 13,800  
 Efficacy 125.5 LPW  
 Color Accuracy 80 CRI  
 L70 Accuracy 50,000

## LED Info

Input Voltage 100-277V  
 Power Factor 0.9  
 Flicker <30%  
 THDi <20%  
 R9

## Technical Specifications

### Listings

**UL Listed:**

Yes

**UL Classified:**

Yes

**FCC:**

Yes

**Rohs:**

Yes

**CEC Status:**

Lawful for sale in California

**DLC Qualified:**

Yes

**DLC Listed:**

This product is on the Design Lights Consortium (DLC) Qualified Products List and is eligible for rebates from DLC Member Utilities. DLC Product Code: POTO54B5

### Description

**Lamp Type:**

HID

**Bulb Type:**

Shoe Box

**Base Type:**

EX39, Mogul Base

**Dimmable:**

No

### Construction

**Operating Temperature:**

-20 - 40°C

**Bare Lamp Illuminated Length (inches):**

7.17"

**MOL (inches):**

11.1"

### MOD (inches):

4.92"

**Minimum Compartment Size (inches):**

Length: 11.02"

Width: 11.02"

Height: 9.84"

### LED Characteristics

**Lifespan:**

50,000-hour LED lifespan based on IES LM-70 results

### Optical

**Beam Angle:**

180°

### Other

**Warranty:**

5-years

# HID-110-H-EX39-850-BYP-SB

## Technical Specifications (continued)

### Other

#### Accessories:

Surge protector available. Click [here](#) for surge protector accessory. Sold separately.

### Shipping Information

#### Case Qty:

6

#### Case Dimensions:

17.52 x 13.27 x 13.58

#### Pallet Quantity of Pieces:

72

#### Pallet Dimensions:

28.5 x 37.01 x 45.47

## Dimensions

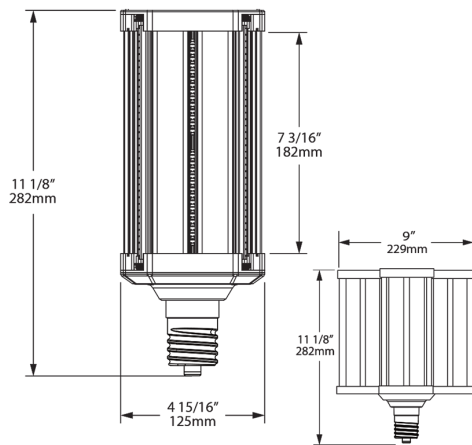

## Features

- HID REPLACEMENT - Replacement for conventional HID lamps
- BALLAST BYPASS - Internal driver eliminates the need for external driver or ballast
- COMPACT DESIGN - Allows the lamp to fit in most fixtures
- EXPANDABLE FLAPS - Provides the light where you need it
- HEAT DISSIPATION - Thermal technology extends lifespan
- WATER & DUST RESISTANT - Ideal for outdoor fixtures
- ENCLOSED FIXTURE RATED - May be used in enclosed and open fixtures
- ENERGY SAVINGS - Uses 76% less energy than traditional lamps
- SURGE PROTECTION - Includes 4kV surge protection
- MERCURY FREE - Environmentally friendly vs fluorescent technologies
- 350°; ROTATABLE BASE - Direct light where needed

## Ordering Matrix

Family	Lamp Power	Orientation	Base Type	CRI	Color Temp	Installation Type	Lamp Type
HID	110	H	EX39	8	50	BYP	SB
	80 = 320W 110 = 400W	H = Horizontal	EX39 = EX39	8 = 80 CRI	30 = 3000K 40 = 4000K 50 = 5000K	BYP = Bypass	SB = Shoebox