

# AL-01 SERIES AREA LIGHTS



AL-01-BRS



# AREA LIGHTS AL-01 SERIES



TYPE

## SPECIFICATIONS

**CONSTRUCTION:** Cast aluminum or cast brass China Hat; matching extruded aluminum or brass stanchion

**LAMP SUPPLIED:** 18w S8 #1141; 1200 hours average rating (25w max.)

**LAMP OPTIONS:** We recommend 3w 50,000 hours average rating OMNI-3 LED (-LED3) or OMNI-3 Super Saver (-LED3SS) 10,000 hours average rating 20w Xenon (-X) or 20w Halogen (-H)

**SOCKET:** Single contact bayonet, brass nickel plated lamp socket screw shell (Ba15s); double contact bayonet base (Ba15d) for 120v, both with 200°C silicone lead wires

**WIRING:** Black 3 foot 18/2 zip cord from base of fixture (12v only)  
For 25 foot 16/2 fixture lead wire add -25F to catalog number.  
120v Standard wiring

**CONNECTION:** FA-05 Quick Connector (not supplied) from fixture to main cable (12/2, 10/2 or 8/2 only) 12v only

**MOUNTING:** FA-03 black 9" ABS stake, tapped 1/2" NPS

**FINISH:** Aluminum-Black texture polyester powder coat. Optional finishes available.  
Brass-Unfinished brass. Optional finishes available.

## ORDERING INFORMATION

CATALOG NO.	DESCRIPTION	LAMP	SHIP WEIGHT
AL-01-BLT	Cast Aluminum 5.5" China Hat	18w S8 #1141	2.0 lbs.
AL-01-BRS	Cast Brass 5.5" China Hat	18w S8 #1141	3.0 lbs.
AL-01-SM-BLT	Cast Aluminum 3.75" China Hat	18w S8 #1141	2.0 lbs.
AL-01-SM-BRS	Cast Brass 3.75" China Hat	18w S8 #1141	3.0 lbs.

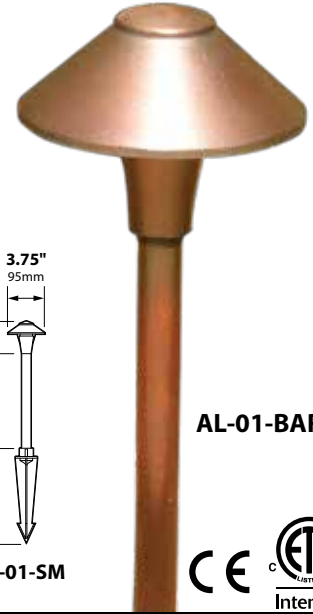

AL-01-BAR

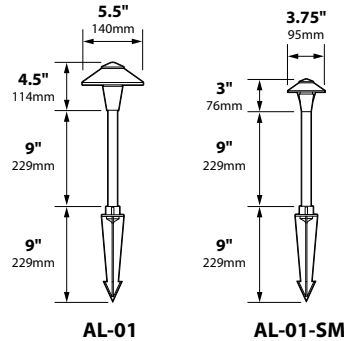

## MOUNTING ACCESSORIES

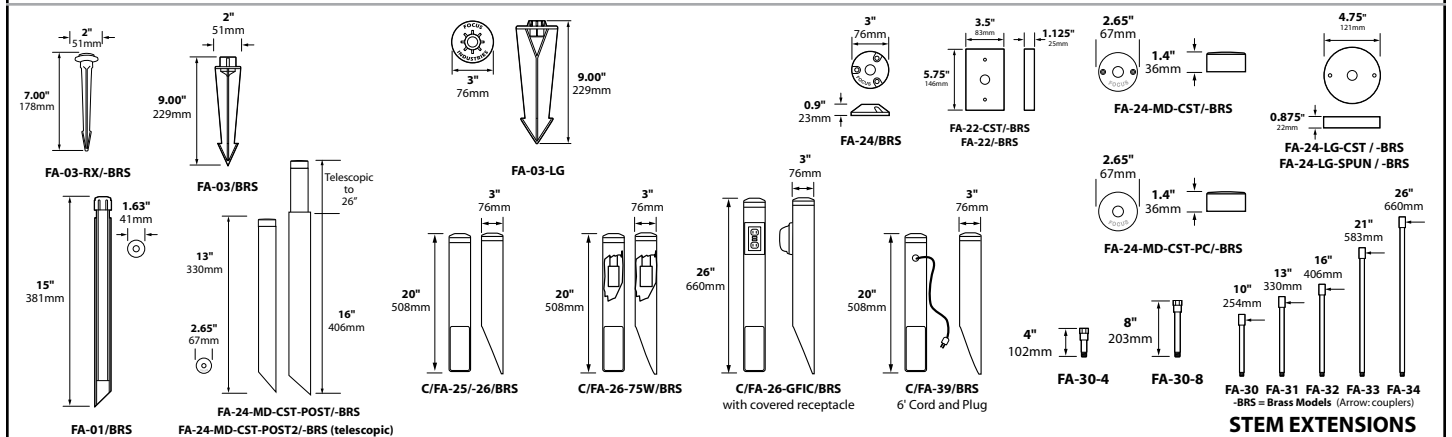

## BEAM/GLARE CONTROL ACCESSORIES

- FA-97-1 AL-01 Sprinkler Guard / Glare Shield
- FA-97-01SM AL-01-SM Sprinkler Guard / Glare Shield
- AH Add to catalog # for Adjustable Hub

## LIGHT DISTRIBUTIONS AND PHOTOMETRICS

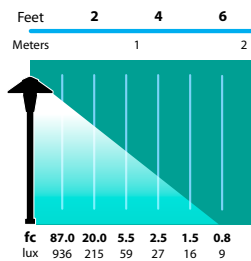

**AL-01**  
Half Spread Photometrics  
12 ft. (3.7m) diameter

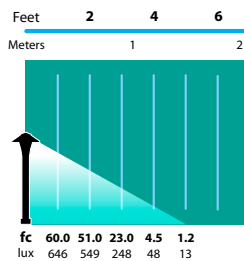

**AL-01-SM**  
Half Spread Photometrics  
10 ft. (3.0m) diameter

## JOB INFORMATION

Type: \_\_\_\_\_ Date: \_\_\_\_\_

Job Name: \_\_\_\_\_

Cat. No.: \_\_\_\_\_

Lamp(s): \_\_\_\_\_

Specifier: \_\_\_\_\_

Contractor: \_\_\_\_\_

Notes: \_\_\_\_\_

Black Texture (Standard)	Antique Verde	Bronze Texture	Camel	White Texture	Hunter Texture	Rust	Weathered Iron	Weathered Brown	Stucco	Rubbed Verde	Chrome Powder	Acid Rust	Acid Verde	Black Acid Treatment
-BLT	-ATV	-BRT	-CAM	-WTX	-HTX	-RST	-WIR	-WBR	-STU	-RBV	-CPR	-BAR/CAR	-BAV/CAV	-BAT