

# BARBECUE LIGHTS: MINI ROUND BACK BQ-FC04 CLAMP SERIES

**TYPE**

## SPECIFICATIONS

- CONSTRUCTION:** 316 stainless steel housing  
**ARM:** 12" tall 316 stainless steel rigid stem with a 16" stainless steel flex arm on top and clear weatherproof polyolefin cover over flex arm  
**MOUNT:** 3" (max opening 2") or 5" (max opening 3.5") stainless steel clamp  
**FINISH:** Stainless Steel – Brushed  
**LENS:** High impact clear tempered flat glass  
**O-RING:** High temperature red silicone, 70 durometer  
**SWITCH:** On/Off push button with weatherproof rubber boot cover

### 12v ELECTRICAL SPECIFICATIONS:

- LED SUPPLIED:** 3w MR11 GU5.3 Super Saver (L-68)  
 40,000 hours average rating  
**SOCKET:** High temperature ceramic GU5.3 bi-pin,  
 250°C silicone insulated lead wires  
**WIRING:** Black 10 foot 18/2 zip cord from base of fixture (12v only)  
 For 25 foot 16/2 wire add-25F to catalog number

## ORDERING INFORMATION

CATALOG NO.	DESCRIPTION	LAMP	SHIP WEIGHT
<b>12v</b> <b>BQFC304L68SS</b>	3" Clamp Mount BBQ Light	3w MR11 LED SS	4.0 lbs.
<b>BQFC504L68SS</b>	5" Clamp Mount BBQ Light	3w MR11 LED SS	4.0 lbs.

## ACCESSORIES

<b>FA-BQCOVER</b>	Vinyl Protective Cover For Flex-Arm BQ Lights w/ Drawstring Closure
-------------------	--



FC3 3"Clamp



FC5 5"Clamp

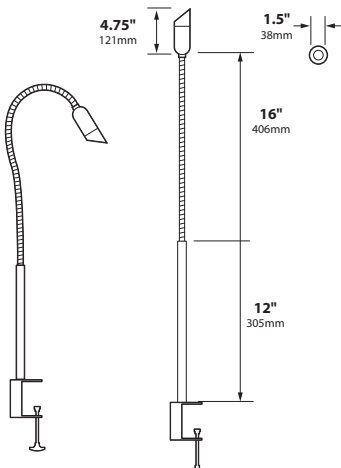

JOB INFORMATION	
Type:	Date:
Job Name:	
Cat. No.:	
Lamp(s):	
Specifier:	
Contractor:	
Notes:	