

MD1NTB



Durable die-formed steel frame and housing comes in a variety of colors and sizes making it easy to add multi-head recessed lighting to new construction projects

Color: Black

Weight: 7.8 lbs

Project:

Type:

Prepared By:

Date:

Technical Specifications

Listings

UL Listing:

Suitable for damp locations

Construction

Housing Component:

This component must be ordered with the Multi-Head gear tray in order to make a complete fixture.

Housing:

Professional-grade, heavy-gauge steel construction with 1/2" trim and three adjustment heights for gear trays.

Mounting:

Housing includes nailer bars and butterfly brackets. Brackets also accommodate mounting with 1/4" to 1/2" bar stock, C channel or 1/2" conduit.

Easy Installation:

Ceiling clamps install quickly and hold housing securely. Clamp ceilings from 1/2" to 2 1/2" thick, with course and fine adjustments.

Other

Trim:

1/2" Trim

Warranty:

RAB warrants that our LED products will be free from defects in materials and workmanship for a period of five (5) years from the date of delivery to the end user, including coverage of light output, color stability, driver performance and fixture finish.

Country of Origin:

Designed by RAB in New Jersey and assembled in the USA by RAB's IBEW Local 3 workers.

Buy American Act Compliant:

This product is a COTS item manufactured in the United States, and is compliant with the Buy American Act.

Recovery Act (ARRA) Compliant:

This product complies with the 52.225-21 "Required Use of American Iron, Steel, and Manufactured Goods-- Buy American Act-- Construction Materials (October 2010).

Trade Agreements Act Compliant:

This product is a COTS item manufactured in the United States, and is compliant with the Trade Agreements Act.

GSA Schedule:

Suitable in accordance with FAR Subpart 25.4.

MD1NTB

Dimensions

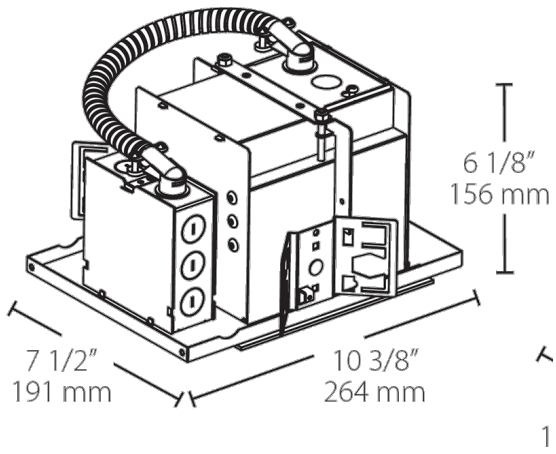

Features

Adjustable clamps for quick, secure installation

Accommodates ceilings 1/2" - 2 1/2" thick

Butterfly bracket allows mounting with bar stock, "C" channel, 1/2" conduit or nailer bars

MD2NTB



Durable die-formed steel frame and housing comes in a variety of colors and sizes making it easy to add multi-head recessed lighting to new construction projects

Color: Black

Weight: 9.7 lbs

Project:

Type:

Prepared By:

Date:

Technical Specifications

Listings

UL Listing:

Suitable for damp locations

Construction

Housing Component:

This component must be ordered with the Multi-Head gear tray in order to make a complete fixture.

Housing:

Professional-grade, heavy-gauge steel construction with 1/2" trim and three adjustment heights for gear trays.

Mounting:

Housing includes nailer bars and butterfly brackets. Brackets also accommodate mounting with 1/4" to 1/2" bar stock, C channel or 1/2" conduit.

Easy Installation:

Ceiling clamps install quickly and hold housing securely. Clamp ceilings from 1/2" to 2 1/2" thick, with course and fine adjustments.

Other

Trim:

1/2" Trim

Warranty:

RAB warrants that our LED products will be free from defects in materials and workmanship for a period of five (5) years from the date of delivery to the end user, including coverage of light output, color stability, driver performance and fixture finish.

Country of Origin:

Designed by RAB in New Jersey and assembled in the USA by RAB's IBEW Local 3 workers.

Buy American Act Compliant:

This product is a COTS item manufactured in the United States, and is compliant with the Buy American Act.

Recovery Act (ARRA) Compliant:

This product complies with the 52.225-21 "Required Use of American Iron, Steel, and Manufactured Goods-- Buy American Act-- Construction Materials (October 2010).

Trade Agreements Act Compliant:

This product is a COTS item manufactured in the United States, and is compliant with the Trade Agreements Act.

GSA Schedule:

Suitable in accordance with FAR Subpart 25.4.

MD2NTB

Dimensions

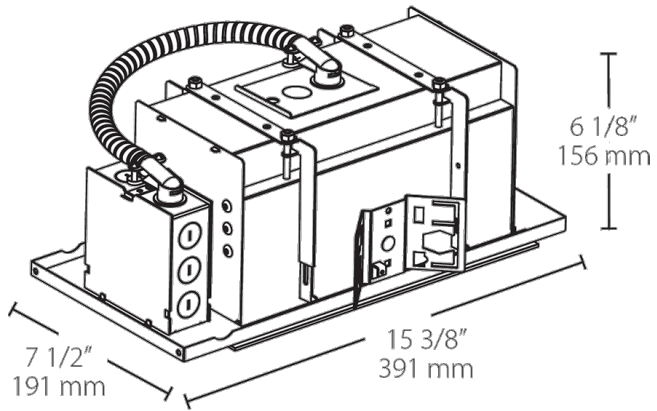

Features

Adjustable clamps for quick, secure installation

Accommodates ceilings 1/2" - 2 1/2" thick

Butterfly bracket allows mounting with bar stock, "C" channel, 1/2" conduit or nailer bars

MD3NTB



Durable die-formed steel frame and housing comes in a variety of colors and sizes making it easy to add multi-head recessed lighting to new construction projects

Color: Black

Weight: 11.8 lbs

Project:	Type:
Prepared By:	Date:

Technical Specifications

Listings

UL Listing:

Suitable for damp locations

Construction

Housing Component:

This component must be ordered with the Multi-Head gear tray in order to make a complete fixture.

Housing:

Professional-grade, heavy-gauge steel construction with 1/2" trim and three adjustment heights for gear trays.

Mounting:

Housing includes nailer bars and butterfly brackets. Brackets also accommodate mounting with 1/4" to 1/2" bar stock, C channel or 1/2" conduit.

Easy Installation:

Ceiling clamps install quickly and hold housing securely. Clamp ceilings from 1/2" to 2 1/2" thick, with course and fine adjustments.

Other

Trim:

1/2" Trim

Warranty:

RAB warrants that our LED products will be free from defects in materials and workmanship for a period of five (5) years from the date of delivery to the end user, including coverage of light output, color stability, driver performance and fixture finish.

Country of Origin:

Designed by RAB in New Jersey and assembled in the USA by RAB's IBEW Local 3 workers.

Buy American Act Compliant:

This product is a COTS item manufactured in the United States, and is compliant with the Buy American Act.

Recovery Act (ARRA) Compliant:

This product complies with the 52.225-21 "Required Use of American Iron, Steel, and Manufactured Goods-- Buy American Act-- Construction Materials (October 2010).

Trade Agreements Act Compliant:

This product is a COTS item manufactured in the United States, and is compliant with the Trade Agreements Act.

GSA Schedule:

Suitable in accordance with FAR Subpart 25.4.

Dimensions

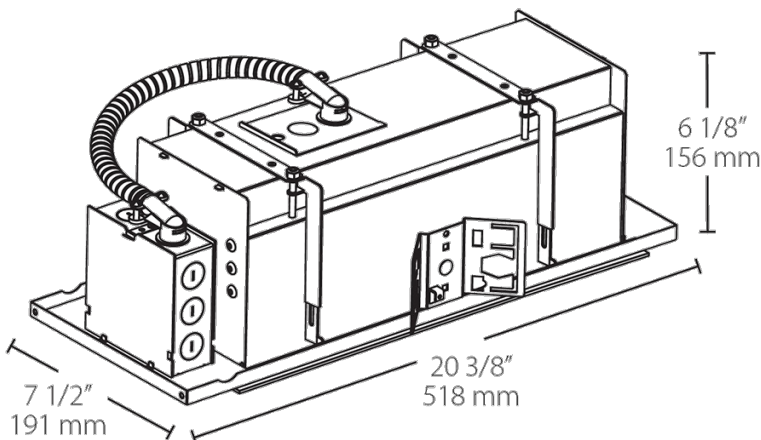

Features

Adjustable clamps for quick, secure installation

Accommodates ceilings 1/2" - 2 1/2" thick

Butterfly bracket allows mounting with bar stock, "C" channel, 1/2" conduit or nailer bars

MD4NTB



Durable die-formed steel frame and housing comes in a variety of colors and sizes making it easy to add multi-head recessed lighting to new construction projects

Color: Black

Weight: 14.1 lbs

Project:

Type:

Prepared By:

Date:

Technical Specifications

Listings

UL Listing:

Suitable for damp locations

Construction

Housing Component:

This component must be ordered with the Multi-Head gear tray in order to make a complete fixture.

Housing:

Professional-grade, heavy-gauge steel construction with 1/2" trim and three adjustment heights for gear trays.

Mounting:

Housing includes nailer bars and butterfly brackets. Brackets also accommodate mounting with 1/4" to 1/2" bar stock, C channel or 1/2" conduit.

Easy Installation:

Ceiling clamps install quickly and hold housing securely. Clamp ceilings from 1/2" to 2 1/2" thick, with course and fine adjustments.

Other

Trim:

1/2" Trim

Warranty:

RAB warrants that our LED products will be free from defects in materials and workmanship for a period of five (5) years from the date of delivery to the end user, including coverage of light output, color stability, driver performance and fixture finish.

Country of Origin:

Designed by RAB in New Jersey and assembled in the USA by RAB's IBEW Local 3 workers.

Buy American Act Compliant:

This product is a COTS item manufactured in the United States, and is compliant with the Buy American Act.

Recovery Act (ARRA) Compliant:

This product complies with the 52.225-21 "Required Use of American Iron, Steel, and Manufactured Goods-- Buy American Act-- Construction Materials (October 2010).

Trade Agreements Act Compliant:

This product is a COTS item manufactured in the United States, and is compliant with the Trade Agreements Act.

GSA Schedule:

Suitable in accordance with FAR Subpart 25.4.

Dimensions

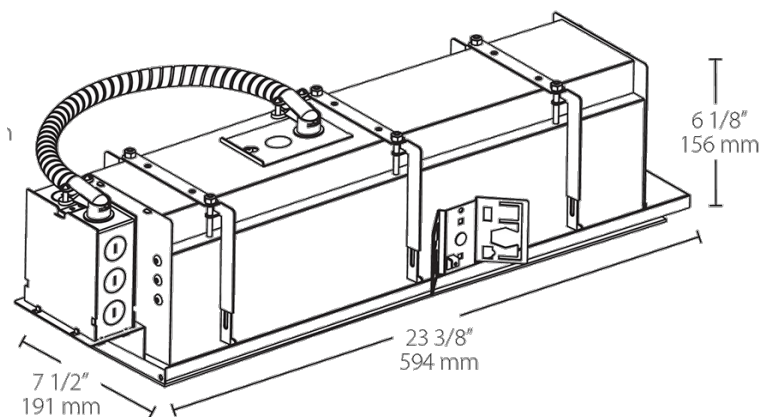

Features

Adjustable clamps for quick, secure installation

Accommodates ceilings 1/2" - 2 1/2" thick

Butterfly bracket allows mounting with bar stock, "C" channel, 1/2" conduit or nailer bars